

CRATE
ACOUSTIC

CA125D

Acoustic Amplifier



User's Guide



CA125D Acoustic Amplifier

Table of Contents:

About the Crate Acoustic CA125D 3

The Front Panel 4

The Rear Panel..... 5

To Eliminate Instrument Feedback..... 6

The DSP Section 6

The Tilt Back Feature 7

System Block Diagram 7

Technical Specifications..... back cover

Declaration of Conformity

Manufacturer's Name: SLM Electronics
Corporate Headquarters: 1901 Congressional Drive, St. Louis, Missouri 63146
Primary Production Facility: 700 Hwy 202 W, Yellville, Arkansas, 72687

Product Type: Audio Amplifier

Products meet the regulations for compliance marking under:

ETL standards UL6500, UL60065, or UL813
 CSA standards E60065 or C22.2 No.1-M90
 CE safety standard EN60065
 CE EMC standards EN55103 or EN55013 and EN61000
 FCC standards 47CFR 15.107 and 15.109 Class A
 C-tick designation Level 2, ABN #56748810738, ARBN# N222
 KETI standard K60065 (limited model approval)

Compliance Support Contact: SLM Electronics, Attn: R&D Compliance Engineer
 1901 Congressional Drive, St Louis, Missouri, 63146 • Tel.: 314-569-0141, Fax: 314-569-0175

CAUTION
 RISK OF ELECTRIC SHOCK
 DO NOT OPEN

WARNING: TO REDUCE THE RISK OF FIRE OR ELECTRIC SHOCK DO NOT EXPOSE THIS APPARATUS TO RAIN OR MOISTURE. TO REDUCE THE RISK OF ELECTRIC SHOCK DO NOT REMOVE COVER. NO USER-SERVICEABLE PARTS INSIDE. REFER SERVICING TO QUALIFIED SERVICE PERSONNEL.

PRECAUCION
 RIESGO DE CORRIENTAZO
 NO ABRA

PRECAUCION: PARA REDUCIR EL RIESGO DE INCENDIOS O DESCARGAS ELECTRICAS, NO PERMITA QUE ESTE APARATO QUEDA EXPUESTO A LA LLUVIA O LA HUMEDAD. PARA DISMINUIR EL RIESGO DE CORRIENTAZO, NO ABRA LA CUBIERTA, NO HAY PIEZAS ADEENTRO QUE EL USUARIO PUEDE REPARAR DEJE TODO MANTENIMIENTO A LOS TECNICOS CALIFICADOS.

ATTENTION
 RISQUE D'ELECTROCUTION
 NE PAS OUVRIR

ATTENTION: PROTEGEZ CET APPAREIL DE LA PLUIE ET DE L'HUMIDITE AFIN D'EVITER TOUT RISQUE D'INCENDIE OU D'ELECTROCUTION. POUR REDUIRE D'ELECTROCUTION NE PAS ENLEVER LE COUVERCLE. AUCUNE PIECE INTERNE N'EST REPARABLE PAR L'UTILISATEUR. POUR TOUTE REPARATION, S'ADRESSEZ A UN TECHNICIEN QUALIFIE.

IMPORTANT SAFETY INSTRUCTIONS

- READ, FOLLOW, HEED, AND KEEP ALL INSTRUCTIONS AND WARNINGS.
- DO NOT OPERATE NEAR ANY HEAT SOURCE AND DO NOT BLOCK ANY VENTILATION OPENINGS ON THIS APPARATUS. FOR PROPER OPERATION, THIS UNIT REQUIRES 3" (75CM) OF WELL VENTILATED SPACE AROUND HEATSINKS AND OTHER AIR FLOW PROVISIONS IN THE CABINET.
- DO NOT USE THIS APPARATUS NEAR SPLASHING, FALLING, SPRAYING, OR STANDING LIQUIDS.
- CLEAN ONLY WITH LINT-FREE DAMP CLOTH AND DO NOT USE CLEANING AGENTS.
- ONLY CONNECT POWER CORD TO A POLARIZED, SAFETY GROUNDED OUTLET WIRED TO CURRENT ELECTRICAL CODES AND COMPATIBLE WITH VOLTAGE, POWER, AND FREQUENCY REQUIREMENTS STATED ON THE REAR PANEL OF THE APPARATUS.
- PROTECT THE POWER CORD FROM DAMAGE DUE TO BEING WALKED ON, PINCHED, OR STRAINED.
- UNPLUG THE APPARATUS DURING LIGHTNING STORMS OR WHEN UNUSED FOR LONG PERIODS OF TIME.
- ONLY USE ATTACHMENTS, ACCESSORIES, STANDS, OR BRACKETS SPECIFIED BY THE MANUFACTURER FOR SAFE OPERATION AND TO AVOID INJURY.
- WARNING: TO REDUCE THE RISK OF ELECTRIC SHOCK OR FIRE, DO NOT EXPOSE THIS UNIT TO RAIN OR MOISTURE.
- SERVICE MUST BE PERFORMED BY QUALIFIED PERSONNEL.
- OUR AMPLIFIERS ARE CAPABLE OF PRODUCING HIGH SOUND PRESSURE LEVELS. CONTINUED EXPOSURE TO HIGH SOUND PRESSURE LEVELS CAN CAUSE PERMANENT HEARING IMPAIRMENT OR LOSS. USER CAUTION IS ADVISED AND EAR PROTECTION IS RECOMMENDED IF UNIT IS OPERATED AT HIGH VOLUME.



EXPLANATION OF GRAPHICAL SYMBOLS:
 EXPLICACION DE SIMBOLOS GRAFICOS:
 EXPLICATION DES SYMBOLES GRAPHIQUES:

= "DANGEROUS VOLTAGE"
 "VOLTAJE PELIGROSO"
 "DANGER HAUTE TENSION"

= "IT IS NECESSARY FOR THE USER TO REFER TO THE INSTRUCTION MANUAL"
 "ES NECESARIO QUE EL USUARIO SE REFIERA AL MANUAL DE INSTRUCCIONES."
 "REFERREZ-VOUS AU MANUAL D'UTILISATION"

About the Crate Acoustic CA125D:

Designed for the performing artist, Crate's *CA125D Acoustic Amplifier* gives you **more** of what you want. More power. More clarity. More control. And, more freedom. Imagine: microphone quality sound, *without feedback*. And without being "chained" to a mic stand!

More power: twin 50-watt RMS power amplifiers drive a pair of specially designed high fidelity 8" low frequency transducers for plenty of volume and low end punch.

More clarity: a separate 25-watt RMS power amp drives a highly efficient Piezo tweeter for clean crisp highs and natural midrange blend. A tweeter level control on the rear panel allows you to adjust the high frequency output to suit your taste.

More control: three independent channels, each with its own gain and reverb/effects controls. The main Instrument channel features an "Active/Piezo" switch to properly match the pickups of your instrument, plus a three-band rotary EQ with variable contour – for total control of the critical midrange frequencies. An easy-to-use feedback elimination circuit with frequency select and cut controls lets you kill feedback without sacrificing sound quality. Plus a footswitchable chorus with depth and rate controls.

The Vocal/Aux channel offers both low and high impedance inputs for both kinds of microphones, with phantom power on the Low-Z input. The third "Aux" channel allows the use of a rhythm machine, background tape, or another mic or instrument.

Still more: The master section features reverb and effects return controls, a five-band graphic EQ, and the master level control. A footswitch jack on the rear panel provides control for reverb and chorus. Level-control-able XLR and 1/4" balanced line outs allow you to patch into house sound boards or recording consoles, plus an effects loop line-in/line-out setup allows connection of external effects.

Enough already? Not for us. The *CA125D* features Crate's *Digital Signal Processing (DSP)* for a variety of digital reverbs, effects and delays specifically designed for acoustic instruments.

The *CA125D* features a flip-out locking bar underneath the cabinet which allows you to tilt the amplifier back for increased coverage and projection.

The *CA125D* was designed, evaluated, tweaked and redesigned by musicians and music loving engineers. Highly sophisticated computer driven assembly machines and highly skilled assemblers use only the finest components to produce each amp. Every cabinet is hand-built and hand-covered by trained craftsmen. The final assembled product is tested – and played – by skilled musician/technicians. It is only *after* the amplifier has passed this barrage of picky people that it gets packed up and shipped out.

The *CA125D Acoustic Amplifier*. Designed to be its best, so you can **sound your best!**

To get this amplifier to sound its best, read this user's guide prior to its use.

To keep this amplifier looking its best, avoid abrasive cleansers. Wipe the cabinet clean using a slightly dampened cloth. Never use brass cleaners on the hardware since they could damage their protective coatings.



The Front Panel:

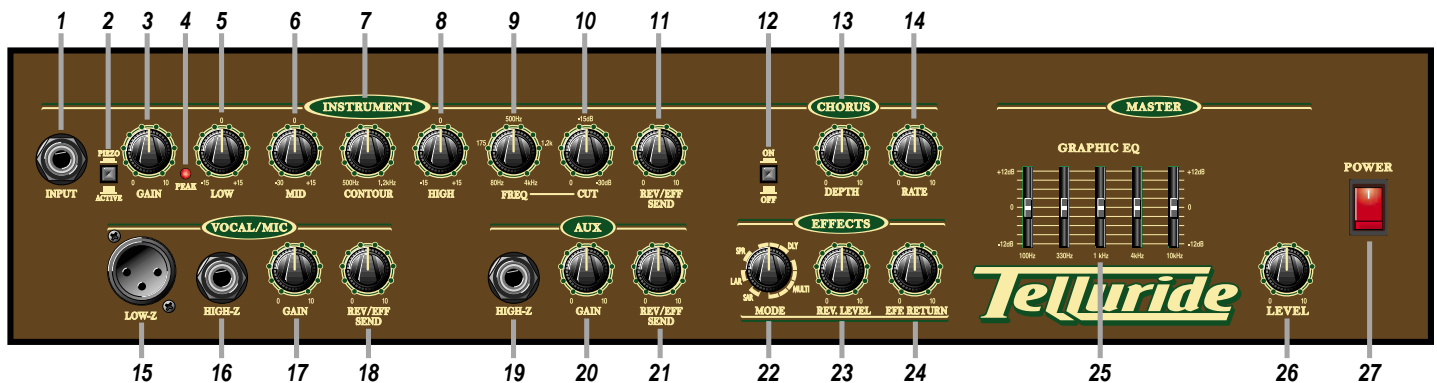

The Instrument Channel:

- 1: **Input.** The signal output from your acoustic instrument may be connected here by means of a shielded instrument cable.
- 2: **Active/Piezo.** Use this switch to match the type of pickup used in your instrument. For active electronic pickups, set the switch to "active" (switch out). For passive/magnetic pickups, set it to "piezo" (switch depressed).
- 3: **Gain.** This serves as the input level control for the instrument channel. For the best signal to noise ratio set this control so the Peak LED (#4) flashes on strong signals.
- 4: **Peak.** This LED flashes when the signal level into the preamp approaches clipping. Adjust the Gain control (#3) until a strong signal causes this LED to flash.
- 5: **Low.** This serves as the instrument channel's primary bass control. Adjust this control to get the best sounding bass response for your instrument. Excessive boost of the low control can cause an unnatural howling and should be avoided.
- 6: **Mid.** This serves as the instrument channel's primary midrange control. Adjust this control to get the best projection and midrange tones for your instrument. The center point of the mid control is chosen by the setting of the Contour control (#7).
- 7: **Contour.** Use this control to set the center point of the Mid control (#6). Set this control at the frequency which gives you the most natural-sounding midrange tones.
- 8: **High.** This serves as the instrument channel's primary treble control. Adjust this control so your high notes and harmonic overtones are lively but not overpowering.
- 9: **Freq.** Use this control along with the Cut control (#10) to eliminate instrument feedback. For information on the proper use of this control, please read the section entitled "To Eliminate Feedback."
- 10: **Cut.** Use this control along with the Freq control (#9) to eliminate instrument feedback. For information on the proper use of this control, please read the section entitled "To Eliminate Feedback."
- 11: **Rev/Eff Send.** Use this control to adjust the amount of internal Digital Effect and/or external effect (if used) for Channel 1.
- 12: **On/Off.** This switch, when depressed, applies the internal chorus effect to the instrument channel.
- 13: **Chorus Depth.** Use this control to adjust the magnitude of the chorus effect. Rotating this control clockwise increases the intensity of the effect.
- 14: **Chorus Rate.** Use this control to adjust the rate of the chorus effect. Rotating this control clockwise increases the rate at which the effect occurs.

The Vocal/Aux Channel:

- 15: **Low-Z.** The signal output from a low impedance microphone may be connected here by means of a shielded, balanced microphone cable terminated with an XLR connector. The Low-Z jack has 15 volts phantom power applied to pins 2 and 3. (Mics not requiring phantom power will not be affected.)
- 16: **Hi-Z.** The signal output from a high impedance microphone or a line level signal may be connected here by means of a shielded signal cable terminated with a 1/4" tip/sleeve connector.
- 17: **Gain.** This serves as the input level control for the vocal/aux channel. Adjust this control for the best mix with the signals from the other channels.
- 18: **Rev/Eff Send.** Use this control to adjust the amount of internal reverb and/or external effect (if used) for the vocal/aux channel.

The Aux Channel:

- 19: **Hi-Z.** The signal output from a high impedance microphone or a line level signal may be connected here by means of a shielded signal cable terminated with a 1/4" tip/sleeve connector.
- 20: **Gain.** This serves as the input level control for the aux channel. Adjust this control for the best mix with the signals from the other channels.
- 21: **Rev/Eff Send.** Use this control to adjust the amount of internal reverb and/or external effect (if used) for the aux channel.

The Effects Section:

- 22: **Mode.** Use this control to select the type of digital signal processing applied to the output signal. For a listing of the effects, please see the section entitled "The DSP Section."
- 23: **Rev Level.** Use this control to adjust the amount of the internal reverb. Rotating the control clockwise increases the amount of effect.
- 24: **Eff Return.** Use this control to adjust the amount of effect applied from an external signal processor (if used).

The Master Section:

- 25: **Graphic EQ.** Use these sliders to control the output frequencies indicated below each control. The center position of each control is flat (no boost or cut). Use the graphic EQ to adjust the output of the amplifier to best suit your tastes and to compensate for room acoustics.
- 26: **Level.** use this control to adjust the overall output level of the amplifier.
- 27: **Power.** Use this switch to apply power to the amplifier. The amp is on when the top of the switch is depressed and off when the bottom of the switch is depressed. this switch illuminates when the amplifier is on.

The Rear Panel:

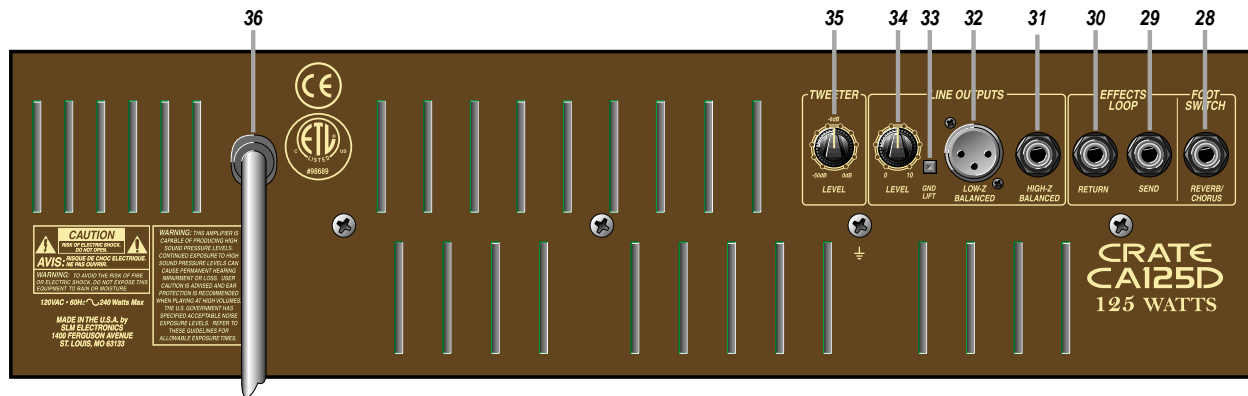

28: Footswitch. Connect the supplied two-button footswitch here for remote on/off control of the internal reverb and chorus. (When connected, the footswitch overrides the front panel chorus on/off switch.)

Note: This is a STEREO jack: tip controls the chorus, ring controls the reverb, sleeve is ground. Use only a footswitch equipped with a *stereo* 1/4" plug.

29: Effects Loop Send. When using an external signal processor, connect this jack to the input of the effect by means of a shielded signal cable.

30: Effects Loop Return. When using an external signal processor, connect this jack to the output of the effect by means of a shielded signal cable.

31: High Z Balanced Line Output. Use this jack to connect a high impedance, line level signal to a house sound board, a recording console or an external power amplifier by means of an 1/4" stereo plug-terminated cable. (Ring is signal +, tip is signal -, and sleeve is ground.)

32: Low Z Balanced Line Output. Use this jack to connect a low impedance, line level signal to a house sound board, a recording console or an external power amplifier by means of an XLR-terminated cable. (Pin 1 is ground, pin 2 is signal +, and pin 3 is signal -.)

33: Gnd Lift. This switch, when depressed, electronically disconnects the Low Z Balanced Output jack's chassis ground connection. If you experience excessive noise when using the Low Z Balanced Output jack, depress this switch.

34: Line Output Level. Use this control to adjust the output level of the line out signal. (This control works independently from the amplifier's master level control.)

35: Tweeter Level. Use this control to adjust the signal output level from the CA125D's internal tweeter. Rotating this control counter-clockwise reduces the tweeter's output level.

36: AC Line Cord. The grounded power cord should only be plugged into a grounded power outlet that meets all applicable electrical codes and is compatible with the voltage, power and frequency requirements stated on the rear panel. **Do not attempt to defeat the safety ground connection!**

To Eliminate Instrument Feedback:

One of the most common problems encountered when amplifying acoustic instruments, especially in small environments, is feedback. Acoustic instruments typically have inherent qualities which cause resonant feedback at specific frequencies. Instrument tone controls and sound board equalizers are helpful in getting rid of the problem, but they typically operate around relatively wide frequency bands. This almost always means the musician must sacrifice sound quality in his quest to do away with feedback. But since Crate's feedback elimination circuit isolates only the offending frequency, instrument feedback from the CA125D can be eliminated without affecting the overall sound.

Chances are, you may not have a problem with feedback at all. In that case, leave the CA120D's Freq and Cut controls fully counter-clockwise. However, if you do encounter feedback while playing, set the Cut control to -30dB (fully clockwise) and adjust the Freq control until the feedback is gone. Reduce the Cut to the 12 o'clock position and readjust the Freq control as needed. Continue reducing the Cut control and readjusting the Freq control until there is no more feedback with the Cut control as far counter-clockwise as possible. This approach effectively eliminates instrument feedback without sacrificing the quality of your sound.

The DSP Section:

The CA125D features Crate's On-Board *Digital Signal Processing (DSP)* technology that was designed specifically for use with acoustic instruments and vocals. This provides a large selection of digital reverbs, effects and delays. Select the type of effect desired by rotating the Mode control (#22). This control is divided into five sections: Small Area Reverbs (SAR), Large Area Reverbs (LAR), Special Reverbs (SPR), Delays (DLY) and Multiple Effects (Multi).



The following chart provides a list of the DSP settings along with a brief description of each effect.

SAR:	Small Room	8' x 8' empty room w/hardwood floor
	Small Rehearsal Hall	20' x 40' hall, wood floors, hard walls
LAR:	Large Hall	50' x 100' hall, about 50 persons
	Concert Hall	5000-seat hall, full crowd
SPR:	Plate Reverb	Simulates studio steel plate reverb
	Spring Reverb	Simulates multi-spring reverb tank
DLY:	Slapback, short	125ms delay + reverb
	Slapback, Med-short	240ms delay + reverb
	Slapback, Medium	350ms delay + reverb
	Slapback, Long	557ms delay - 630' travel time
Multi:	Short Med. Surface	280ms delay w/21.8% regen + reverb
	Medium Hard Surface	335ms delay w/26.5% regen + reverb
	Chor-Delay	400ms delay with modulation
	Chor-Verb	Hall reverb w/modulated pre-delay
	Slap-Verb	Medium hall w/200ms pre-delay
	Instrument Doubler	Simulates second track slightly out-of-sync

The Tilt Back Feature:

There are instances when you may need to tilt the amplifier back to better project its sound towards your ears (as a near-field monitor) or towards your audience (for better coverage). The CA125D features a tilt back device underneath its cabinet for this purpose. To utilize this tilt back feature, refer to the illustration below and follow these simple steps:

- ① Carefully lean the cabinet back - until the front of the cabinet is several inches off the floor.
- ② Pull the tilt back bar down (to unlock it from its holder) and swing it forward until it locks into place.
- ③ Lower the front of the amplifier until it rests on the tilt back bar. (To return the bar to its traveling position, reverse these steps)

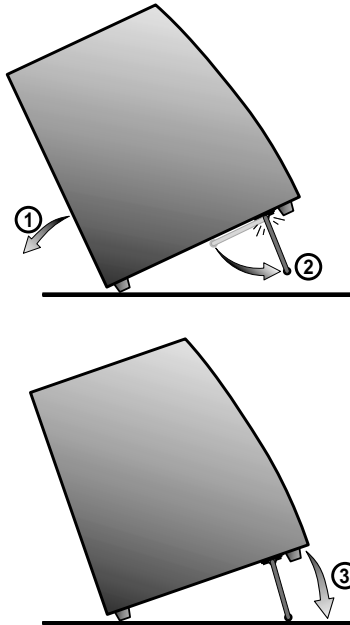

CAUTIONS:

Avoid trapping your hand under the tilt back bar.



Always make sure the bar is securely locked in place before lowering the amplifier.

Do not sit on or rest your foot on the amplifier when it is in the tilt back position.

System Block Diagram:

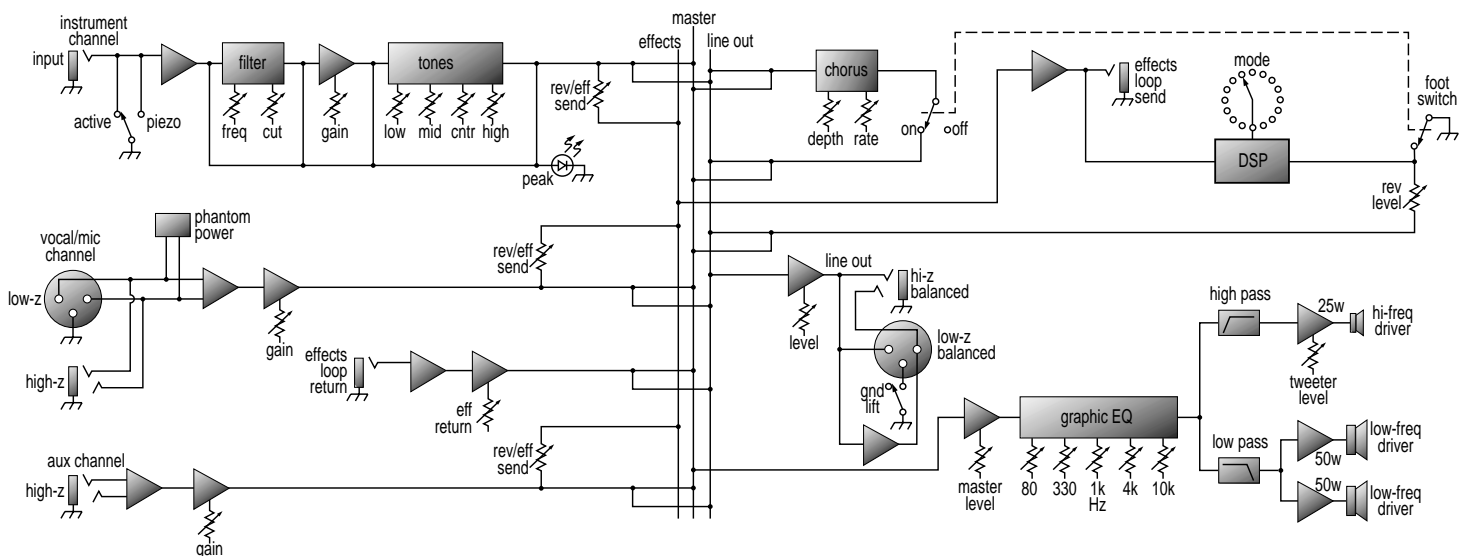

**CRATE
ACOUSTIC**

CA125D Acoustic Amplifier

Technical Specifications:

Output Power Rating: 125 watts RMS total system power

Woofers Amp: 2 x 50 watts RMS @1% THD

Tweeter Amp: 25 watts RMS @1% THD

Inst. Channel: Low: +/-15dB @ 80Hz

Mid: +/-15dB @ 400-1.2kHz (Contour)

High: +/-15dB @ 10kHz

Input Impedance: 25k ohm (Active), 2.2M ohm (Piezo)

Input Sensitivity: 22mV RMS (Active), 9mV RMS (Piezo)

Sens. to Eff Send/Line out: 70mV

Max Input Signal: 6V RMS (17V peak to peak)

Feedback Elimination: Freq: variable from 80Hz to 4kHz
Cut: variable from -0 to -30dB

Voc./Mic Ch: Input Impedance: 3k ohm (Lo-Z), 20k ohm (Hi-Z)

Input Sensitivity: 3mV RMS (Lo-Z), 15mV RMS (Hi-Z)

Sens. to Eff Send/Line out: 9mV (Lo-Z), 50mV (Hi-Z)

Max Input Signal: 10V RMS (28v peak to peak)

Aux. Ch: Input Impedance: 20k ohm

Input Sensitivity: 15mV RMS

Sens. to Eff Send/Line out: 50mV

Max Input Signal: 10V RMS (28V peak to peak)

Master EQ's: +/-12dB @ 80Hz, 330Hz, 1kHz, 4kHz, 10kHz

Effects Loop: Line Out 1V RMS, Line In 1V RMS

Eff Return to Line Out Sens: 50mV

Eff Return In. Impedance: 11k ohm

Eff Send Out. Impedance: 2.2k ohm

Line Out Out. Impedance: 220 ohm (Lo-Z), 2.2k ohm (Hi-Z)

Internal Woofers: 2 x 8" w/polypropylene cones, rubber surrounds, 30oz magnet, 1" voice coil, 8 ohms, 50w RMS, 95dB 1w 1m

Internal Tweeter: High efficiency Piezo, 110dB 1w 1m

Internal Crossover: Active electronic type

Power Requirements: 100VAC, 50/60Hz, 160VA; 120VAC, 60Hz, 160VA; 230VAC, 50Hz, 160VA;
230VAC, 50Hz, 160VA

Size and Weight: 16-3/4"H x 21"W x 10-1/2"D, 42 lbs.

Crate continually develops new products, as well as improves existing ones. For this reason, the specifications and information in this manual are subject to change without notice.



www.crateamps.com

©2004 SLM Electronics
A Division of St. Louis Music Co.
1400 Ferguson Avenue
St. Louis, MO 63133

47-831-05 • 050504

